

BCL Series

**Self-Steering Lift Axle
Air Suspensions**



Efficient New Brake Chamber Lift Design

**Fast-acting chambers are
like air springs in a can.
Easy suspension
installation, easy to service.**



- *Versatile • Single • Multi-Axle Combinations*
- *High-lift • 15" Total Axle Travel, Up to 12 " of Axle Lift*
- *Standard Brake Chambers Lift the Axle*
- *Short 21.8" Spindle to Front of Suspension*
- *Rugged 13,000 lb. Capacity*



BCL Series

Self-Steering Lift Axle Air Suspensions



Versatile, compact and durable self-steering lift axle air suspension for trucks and trailers

- 973 lbs. with a rugged self-steering forged I-beam axle
- Bolt-on crossmember supplied
- with suspension - no welding required at installation
- Wide range of mounting heights
- Inexpensive brake chambers
- provide lift - parts available at all truck equipment stores
- Unique clamped pin pivot connections - secure without bolt torques
- Fast-acting axle lift or loading with high volume air controls
- Truck or trailer applications, on - or off-highway
- High lift - 12" axle lift, 15" total travel
- Easy installation - suspension comes completely preassembled and mounts entirely outside of the truck frame
- Compact 21.8" from center of spindle to front of suspension
- Excellent frame-to-ground clearance - suspension projects only 13.1"-14.8" below the truck frame
- No lift air springs close to the ground like most lift axles
- Easy-to-reach parts for easy maintenance
- 25-degree wheel cut standard for excellent maneuverability
- 5-year limited warranty

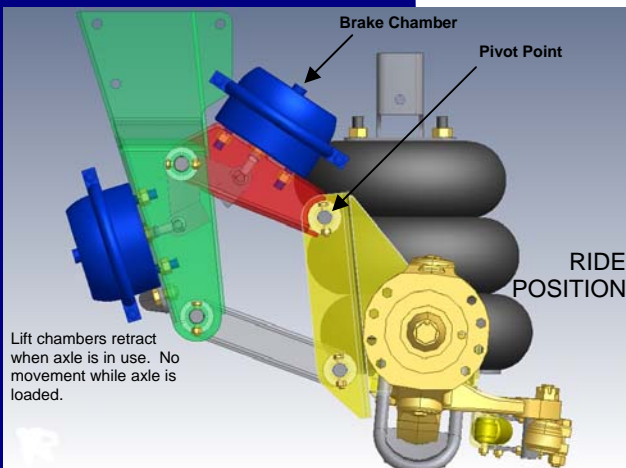
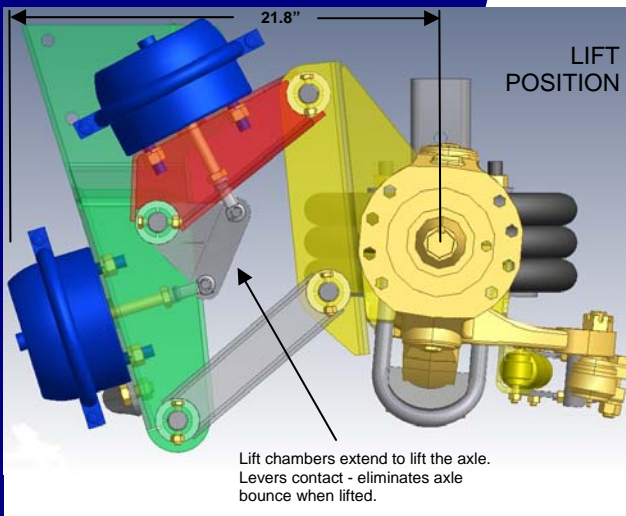

1424 Scale Street SW • Canton, OH 44706
330.458.3058 • 888.877.3058
FAX 330.458.3066 • www.ridesti.com